



NASHUA® 322
General Purpose Aluminum
Foil Tape

APPLICATIONS

- Specially designed for taping joints and seams against moisture and vapor on foil jacketed insulation.
- Appropriate for a variety of insulation uses.
- Used in the automotive industry for general repairs.

FEATURES & BENEFITS

- Tested in accordance with UL 723.
- Dead soft aluminum foil backing is extremely conformable to irregular surfaces.
- Excellent adhesion and quick stick.
- New eco-friendly release liner made from unbleached natural kraft paper.
- Complies with VOC requirements of SCAQMD Rule 1168
- **Contributes toward satisfying EA Credit 1 (Optimize Energy Performance) and EQ Credit 4.1 (Low Emitting Materials, Adhesives & Sealants) under LEED®.**

CONSTRUCTION

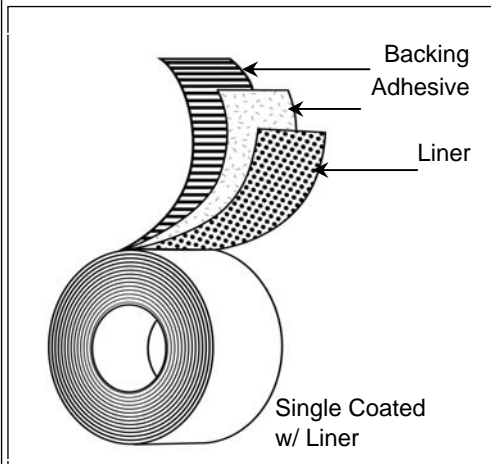

PRODUCT DESCRIPTION

Single-Coated w/Liner Construction

Backing:

- 2 mil Aluminum Foil

Adhesive:

- Synthetic Rubber

Liner:

- Un bleached Natural Kraft Paper

Colors:

- Aluminum

TEST DATA

Test	Typical Value	Typical Value (Metric)	Test Method
Total Thickness	5 mils	127.00 μ	ASTM D-1000
Foil Thickness	2 mils	50.8 μ	ASTM D-1000
Adhesion to Steel	130 oz./in.	14.23 N/cm	PSTC-1
Adhesion to Backing	100 oz./in.	10.95 N/cm	PSTC-1
Tensile Strength	15 lb./in.	26.27 N/cm	ASTM D-1000
Flame Spread	10		
Smoke Developed	15		
Maximum Performance Temperature	200 D F		
VOC Content	<1 g/l		

Recommended storage conditions: 40-60% Humidity, 60°F-80°F

**Products are not reviewed or certified under the LEED® Rating System. LEED® credit requirements cover the performance of materials in aggregate, not the performance of individual products or brands. For more information on LEED®, visit www.usgbc.org/leed.

The information presented herein was prepared at BERRY PLASTICS CORPORATION (25 Forge Parkway Franklin, MA 02038) by qualified technical personnel. Berry Plastics' knowledge it is true and accurate. However, the information and recommendations are furnished for these products with the understanding that the purchaser or user, as the case may be, will independently determine that the product is suitable for the intended use, and that such use complies with all applicable federal, state and local laws and regulations. The data are submitted only for the user's information and consideration, and do not constitute a warranty of any kind (including but not limited to a warranty of merchantability or of fitness for a particular purpose), or a representation for which BERRY PLASTICS assumes any legal responsibility.