



# D9200



## PATCO® D9200 FR Aircraft Waterseal Tape & Corrosion Inhibitor

### APPLICATIONS

- Aircraft waterseal applications in main cabin areas including galleys, entryways, lavatories and any areas that are susceptible to moisture damage.
- Wide widths available for sealing large areas.
- Reinforcing and provide moisture barrier for aircraft insulation fastener opening.

### FEATURES & BENEFITS

- Flame retardant, very tough, elastic, water resistant, and transparent.
- Meets FAR 25.853(a).
- Holds up under heavy use.
- Excellent moisture barrier.
- Repositionable and permanent.
- Extra thickness for stay flat and dimensional stability.
- Transparent to allow for visual inspection.
- Release liner for wide width usage and die-cuts.

### CONSTRUCTION

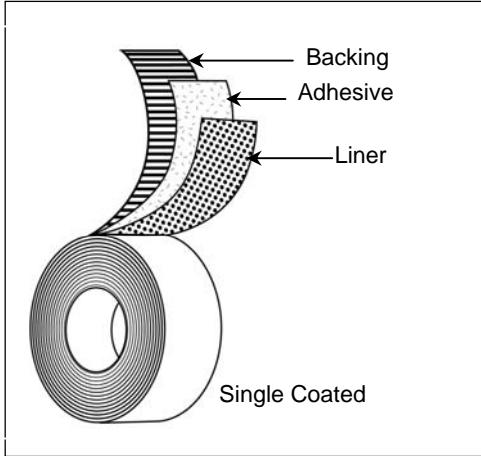

### PRODUCT DESCRIPTION

#### Single-Coated w/Liner Construction

#### Backing:

- Exterior-Grade Aliphatic Polyurethane

#### Adhesive:

- Acrylic

#### Liner:

- Blue HDPE

#### Colors:

- Transparent

### TEST DATA

Test	Typical Value	Typical Value (Metric)	Test Method
Total Thickness	14 mils	.356 mm	PSTC-33
Adhesion to Steel	80 oz./in.	89.6 g/mm	ASTM D-3330
Tensile Strength	90 lb./in.	1.61 kg/mm	ASTM D-3759
Elongation (%)	500 %		
Operating Temperature	-40F to 275F		
Application Temperature	50F to 120F		
Weight	1.411 oz/sq ft		

\*\*Recommended storage conditions: 40-60% Humidity, 60°F-80°F

Typical values are not intended to be used for specification development. Technical data is believed to be true and accurate. We recommend the purchaser test the fitness for use for all applications.

